

EXCAVATOR QUICK CHANGE

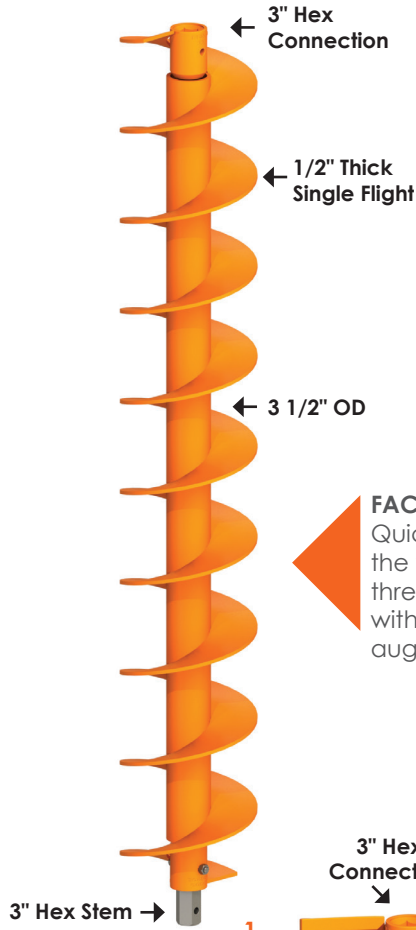

FLIGHT SECTION LENGTHS AVAILABLE:
5', 10' and 20'



FACT: The Excavator Quick Change allows the versatility to use three different heads with either a 5', 10' or 20' auger flight section.



2070 Inside Teeth and 2072 Outside Gage Teeth

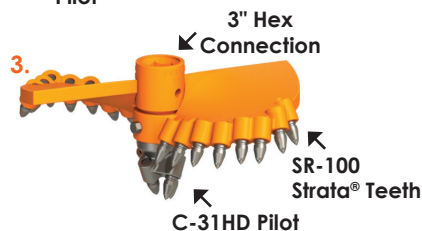
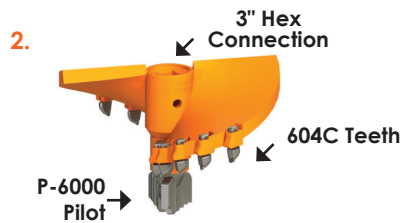

AVAILABLE OPTIONS:

1. **Standard Dirt**
TF-1000 Pilot,
2070Band
2072 Fas-N-Lok®
Teeth
2. **Step Rock**
P-6000 Pilot
and
604C Drag
Style Tooth
3. **Rock Option**
C31-HD Pilot
and
SR-100 STRATA®
Conical Teeth

CONNECTIONS



AUGER DIAMETERS



CUT DIAMETER

NOTE: Excavator Augers are True Cut, cut and tool diameter are equal

DRILLING SOIL CONDITIONS:



Pengo's Excavator Quick Change system is the perfect solution for turning your excavator into a dedicated drilling machine. Regardless of excavator brand or size our quick change system provides maximum flexibility and customization for a tailored made installation. Each system is a total package designed to match your excavator specifications. Featuring Revolution hydraulic drive heads, your choice between end of stick or quick connect mounting systems, multiple length flight bodies, and (3) separate drill head options, you can drill effectively in all soil conditions, from dirt to rock, both fracturable and non-fracturable

EXCAVATOR AUGER



FLIGHT SECTION LENGTHS AVAILABLE:
5', 10' and 20'

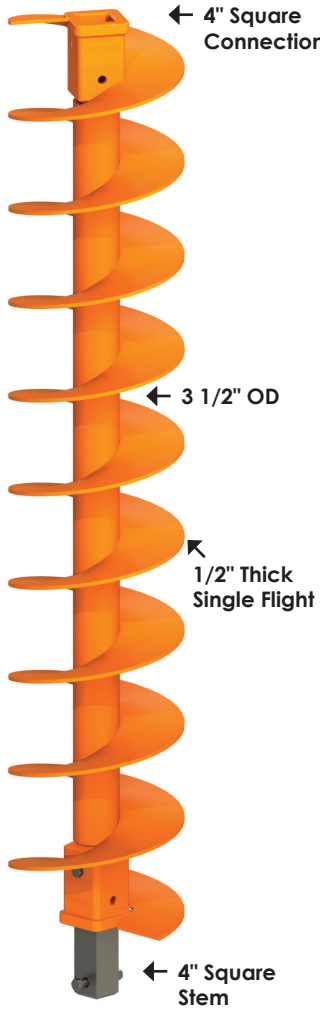

LEAD SECTIONS:
5' OAL Rock or Dirt

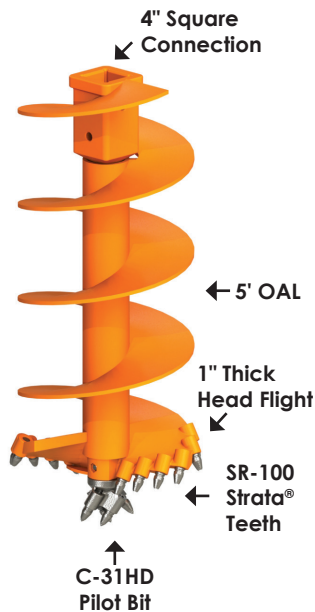

CONNECTIONS

SQUARE 4"

AUGER DIAMETERS

16" 18" 20" 24" 30" 36" 42" 48"

CUT DIAMETER

NOTE: Excavator Augers are True Cut, cut and tool diameter are equal

DRILLING SOIL CONDITIONS:



Pengo continues to provide solutions for our customers. With the introduction of the Revolution Series Drilling drives came the need for a complete excavator auger system. This system is available for both rock and dirt drilling and come in five feet sections. Each five foot section attaches to a five foot, ten foot or twenty foot flight section.

EXCAVATOR AUGER



FLIGHT SECTION LENGTHS AVAILABLE:
5', 10' and 20'

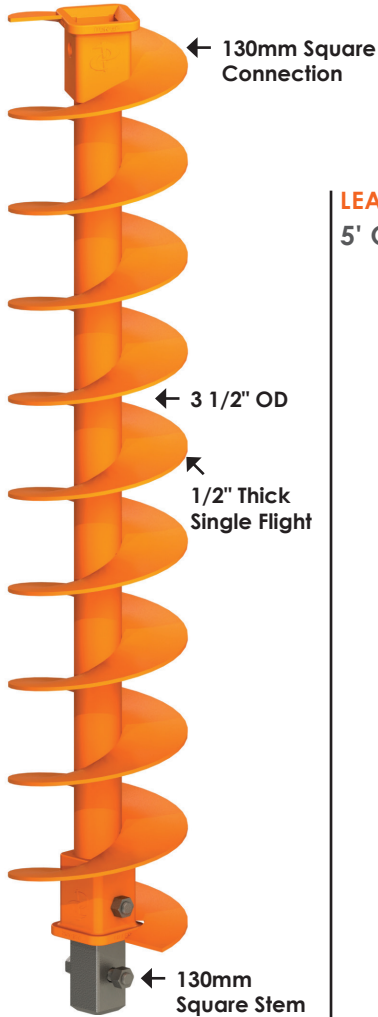

LEAD SECTIONS:
5' OAL Rock or Dirt

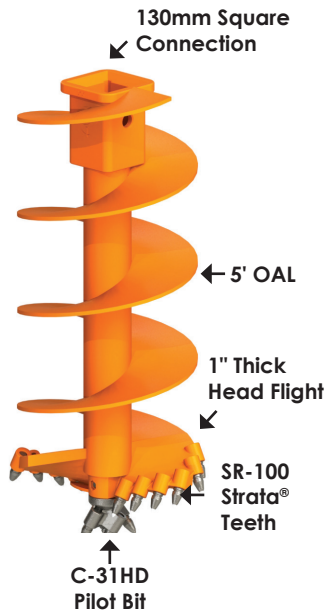

CONNECTIONS



AUGER DIAMETERS



CUT DIAMETER

NOTE: Excavator Augers are True Cut, cut and tool diameter are equal

DRILLING SOIL CONDITIONS:



Pengo continues to provide solutions for our customers. With the introduction of the Revolution Series Drilling drives came the need for a complete excavator auger system. This system is available for both rock and dirt drilling and come in five feet sections. Each five foot section attaches to a five foot, ten foot or twenty foot flight section.