



IMPORTANT!



Variable Speed Auger Drive Units DV-20, DV-30, & DV-40

ACTION REQUIRED!

Variable speed motor **CANNOT BE OPERATED** without being pre-filled with hydraulic fluid. Operating the motor without hydraulic fluid **WILL CAUSE EXTENSIVE DAMAGE**.

The motor has been equipped with quick connect couplers to ensure the motor has fluid at all times. The motor is filled with hydraulic fluid at the factory and is shipped in a ready to use condition.

All DV series units require the use of a motor case drain line. **A 3/4" (ID) CASE DRAIN LINE MUST BE USED TO AVOID DAMAGE TO THE HYDRAULIC MOTOR.**

NOTE: The DV series Auger Drives use a threaded quick coupler on the hydraulic motor. The DV series hydraulic motor must maintain fluid in the motor at all times. These quick couplers ensure that the motor will always maintain a minimum level of fluid. These quick couplers also make connecting to the auxiliary hydraulic circuit easier when residual pressure is present in the line.

These quick couplers should not be replaced by another coupler that does not allow fluid to remain in the motor. Replacing these couplers with a method that does not retain fluid in the motor can lead to damage and will not be covered by warranty.

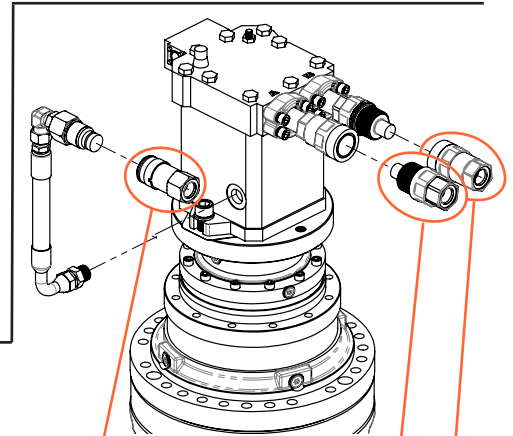

These fittings are provided with the Drive separately. Use these fitting to complete the hoses used on the Prime Mover.

Pressure Port

Tank Port

Ports may vary depending on machine model

Case Drain Line

USE FITTINGS SUPPLIED WITH DRIVE UNIT TO CONNECT MOTOR TO CASE DRAIN WITH A 3/4" (ID) HYDRAULIC HOSE

